

"At the service of foundrymen, driven by innovation"



Electrotherm Plant at Palodia, Ahmedabad

Electrotherm has the state of the art manufacturing facility consisting of machine shops, assembly shops, fabrication shops, and testing facilities. It's world class research and development facility is accredited by department of Science and Technology, Govt. of India for product development, design and engineering. Electrotherm manufactures complete range of melt shop equipment for Foundries and Steel Plants. With more than 4000 installations in India and 34 countries, Electrotherm furnaces are acknowledged as the best in terms of technological innovation and reliability.

THE ULTIMATE
MELTING
PERFORMANCE
for Foundries

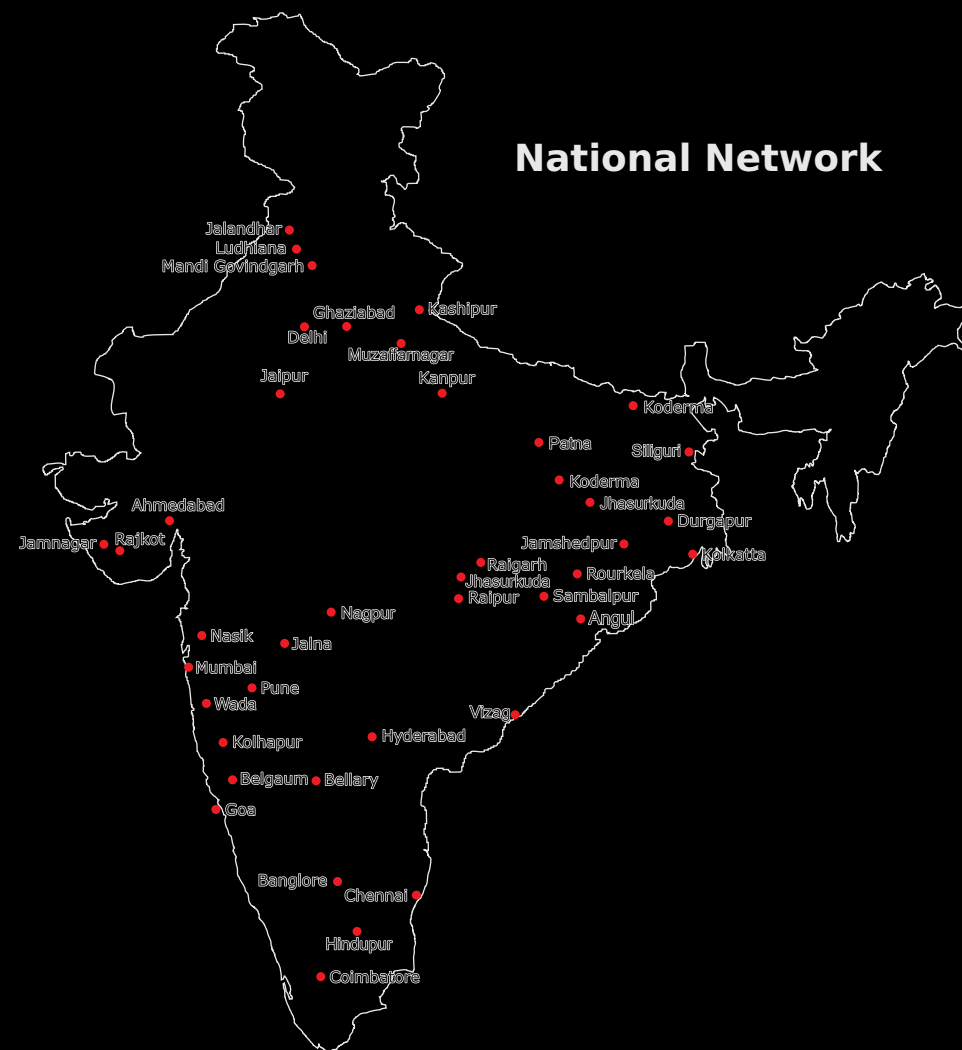

ELECTROTHERM[®] (INDIA) LIMITED

Head Office & Works : 72, Palodia, (Via Thaltej), Ahmedabad – 382 115, Gujarat (INDIA)
Phone : +91-2717- 660550. Fax : +91-2717- 234866
E-mail : mkt@electrotherm.com Website : www.electrotherm.com



Design by rabiant 079-2658243/54

ELECTROTHERM
FURNACES

INDIA'S BEST : GLOBALLY ADMIRER



S-SERIES POWER SUPPLY UNIT

The S series medium frequency power supplies with power ratings from 50 KW to 18000 KW and frequency range of 100 Hz to 4000 Hz have been work horses across the foundries and steel melting plants for their robust design, state of the art technology, efficiency and excellent reliability.

These power supplies adopt compact design and yet are spacious enough to facilitate easier maintenance. The inverter SCRs are well protected by break-over diodes. The current fed inverter design results in higher inverter efficiency compared to other designs. Less number of power components and component types makes the system very simple. The fast electronic tripping devices protect the system in the event of short circuits. The efficient DC Choke ensures safety of power components.

Easy to read system monitor board provides information on system's electric parameters and for trouble shooting and maintenance. A fast acting and highly sensitive earth leak detector is provided for the optimum safety of operator and equipment.



E-SERIES POWER SUPPLY UNIT

The E series medium frequency power supplies have power ratings from 50 KW to 600 KW and frequency range of 500 Hz to 3000 Hz. These power supplies are ideally suited for relatively smaller ferrous and non ferrous foundries with **ET ALUMIN SL** furnaces of capacities up to 1000 Kg. The current fed inverter design results in higher inverter efficiency. Less number of power components and component types makes the system very simple. The fast electronic tripping devices protect the system in the event of short circuits.

Field reports indicate an improvement to the extent up to 7-8% in melt rates and energy consumption for E-Series power supply working in conjunction with **ET ALUMIN SL** furnaces. Easy to read system monitor board provides information on systems electric parameters and trouble shooting and maintenance. A fast acting and highly sensitive earth leak detector is provided for the optimum safety of operator and equipment.



I SERIES - IGBT based Power Supplies

These compactly built power supplies adopt IGBT based design. A high power factor of 0.99 is achieved throughout the melt cycle. Field reports indicate a reduction in energy consumption of up to 3 % due IGBT based design. The system provides 100% isolation from input power in case of short circuit at the output. Modular design facilitates easier maintenance and component replacements. An optional touch screen HMI based front control panel is provided for easier access and view.

EI SERIES - IGBT based Power Supplies

EI Series Power Supplies combine the features of **E Series** and **I Series** and are available in power ratings of 50 KW to 600 KW. These compactly built power supplies adopt IGBT based design. A high power factor of 0.99 is achieved throughout the melt cycle. Field reports indicate a reduction in energy consumption of up to 10% due adoption of EI design. The system provides 100% isolation from input power in case of short circuit at the output. Modular design facilitates easier maintenance and component replacements. An optional touch screen HMI based front control panel is provided for easier access and view.



ET Double -Track

ET Double-Track is the double output power supply available to foundrymen for optimum utilization of installed KVA. These systems allow simultaneous sharing of power between two furnaces in any ratio within the rated power. Infinite power sharing feature has the potential to increase the KVA utilization index by up to 25-30%. Field reports indicate an increased metal output of 25-30% with ET Double – Track compared to single output power supplies.

An optional stand-by crucible can be provided to take care of Double Track operation in the event of any one of the crucibles being under re-lining / sintering / maintenance. The patented PLC controlled switch ensures smooth switch over of power to the stand-by furnace.

Double-Track Concept

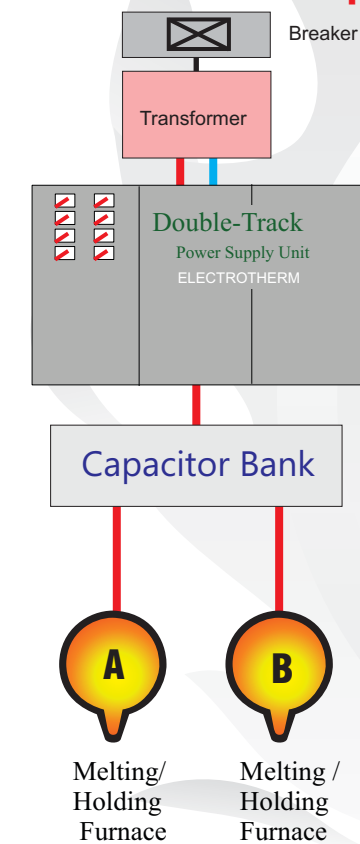

ET Double -Track Plus

ET Double-Track Plus is the most versatile double output power supply available in the market today. These systems allow simultaneous sharing of power between two furnaces in any ratio within the rated power. Infinite power sharing feature has the potential to increase the KVA utilization index by up to 25-30%. Field reports indicate an increased metal output of 25-30% with ET Double - Track Plus compared to single output power supplies.

The unique feature of ET Double-Track Plus is the capability of the system for sharing the power with standby (3rd) furnace, thus ensuring uninterrupted continuation of metal production even when one of the furnaces is under relining/sintering/maintenance. This feature makes ET Double-Track Plus a double output power supply in a real, complete and comprehensive sense of the word making it far superior than any of the competitive product. An ET Double-Track Plus is always a double track, nothing less. The seamless electronic integration completely eliminates need for any kind of mechanical switching for the selection of furnaces.

If need arises at any given point of time for a larger quantum of metal to be made available, power can be given to all the three crucibles simultaneously in the required ratio, within the limits of overall rated power, and the metal from all the three furnaces can be tapped at a time to ensure larger single batch of liquid metal.



POWER SUPPLIES

Double-Track Plus Concept

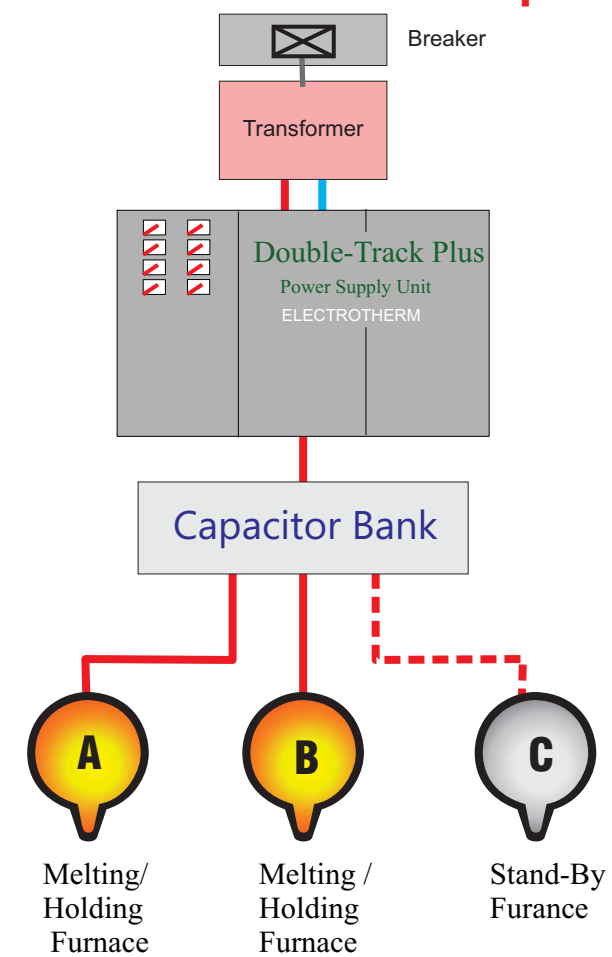



ET Triple-Track

ET Triple-Track is the triple output power supply available to foundrymen for optimum utilization of installed KVA and continuous supply of liquid metal to mould lines. These systems allow simultaneous sharing of power between three furnaces in any ratio within the rated power. Infinite power sharing feature has the potential to increase the KVA utilization index to almost 100%. Field reports indicate an increased metal output of 5% or more compared with Double Track power supplies.

An optional stand-by crucible can be provided to take care of Triple Track operation in the event of any one of the crucibles being under re-lining / sintering / maintenance. The patented PLC controlled switch ensures smooth switch over of power to the stand-by furnace.

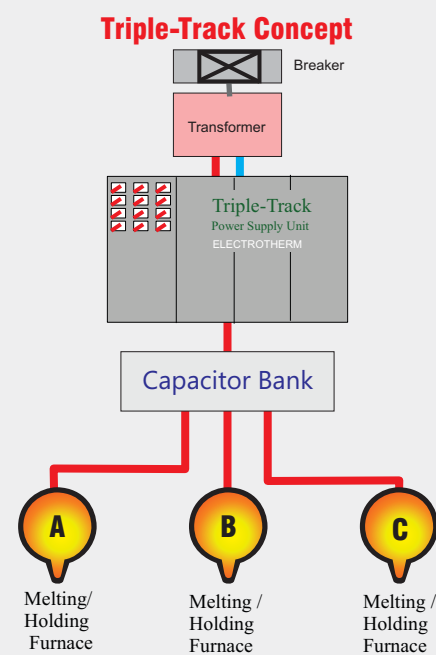

ET Triple - Track Plus

ET Triple-Track Plus is the most versatile triple output power supply available in the market today. These systems allow simultaneous sharing of power between three furnaces in any ratio within the rated power. Infinite power sharing feature has the potential to increase the KVA utilization index to almost 100%. The metal output will increase by 5% or more even as compared to Double-Track Plus.

The unique feature is the capability of the system for sharing power with stand by (4th) furnace, thus ensuring uninterrupted continuation of metal output at the same level even when one of the furnaces is under relining/sintering/maintenance. This feature makes ET Triple-Track Plus a triple output power supply in a real, complete and comprehensive sense of the word making it far superior than any of the competitive product. An ET Triple-Track Plus is always a triple track, nothing less. The seamless electronic integration completely eliminates need for any kind of mechanical switching for the selection of furnaces.

If need arises at any given point of time for a larger quantum of metal to be made available, power can be given to all the four crucibles simultaneously in the required ratio, within the limits of overall rated power, and the metal from all the four furnaces can be tapped at a time to ensure larger single batch of liquid metal.

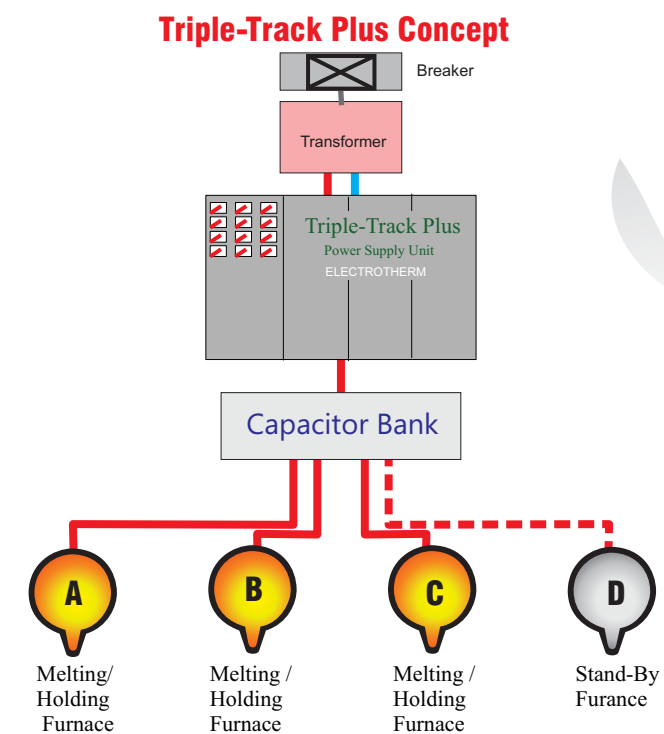



PLC BASED DYNAMIC LOAD MANAGER (PDLM)

- PDLM is used to maintain the constant actual power demand of plant from supply line. If actual KVA tends to exceed the sanctioned KVA, the PDLM reduces the power of induction furnace. By using PDLM, maximum sanctioned KVA can be utilized, which optimizes the overall load factor of the plant.
- When more than one furnaces are in operation on a single grid, PDLM can work still more effectively by sharing the total available power.
- Power to the furnace can be shared through priority selection switches wherein one furnace can be provided full power while other runs at reduced power.
- Overall productivity of plant will increase because of optimum use of available power. No human intervention is required for monitoring and controlling furnace load.
- CT & PT failure protection is provided in the system which reduces power to minimum with an alarm indication.

S-Series, E-Series, I-Series and EI series power supplies of up to 1000 KW rating, working in conjunction with ALUMIN SL furnaces can be offered in the respective **Plus** models with provision of PLC with HMI touch screen display to include features of Load Manager, MD Controller, auto sintering, data acquisition and USB based memory storage of up to 8 MB.



PMA 100 (PLC BASED MELT AUTOMATION WITH HMI PROVISION)

These modules have been introduced with the intention of enabling foundries to derive maximum benefit from the latest state of the art melt automation techniques.

The system features include

- **HMI Display** : The latest version of PLC with 6 inch color HMI. The HMI displays all safety interlocks. Any unhealthy interlock will be easily identified by a corresponding change in the interlock display color.
- Digital display of parameters like voltage, current, power, frequency, earth leakage current and water conductivity.
- Alarm generation of each event like power ON/OFF, trip, interlock failure for fault diagnosis.
- Alarm history for finding the cause of the recurring problems.
- The fault diagnostic features enable a comprehensive check of deviation in critical system parameters including water temperatures, water pressure, electric limits, etc.
- Historical graphical trending of key information like Power vs. Time, Voltage vs. Time, etc.
- Auto sintering facility: A pre determined sintering cycle can be fed into PMA 100 to facilitate automatic sintering for a more accurate sintering. This results in a better lining life.

SPA 100 - SCADA BASED PLANT AUTOMATION

- Implements centralized SCADA (Supervisory Control and Data Acquisition) system for the whole plant.
- Display of all the important parameters pertaining to each furnace, pump house, DG Set, etc. Key furnace parameters include the ones related to electrical system, metal weight, metal temperature, water pressure/flow etc.
- Monitoring on SCADA of all electrical parameters of plant HT & LT feeders.
- Trending, alarm generation, Storage of historical parameters.
- Automatic control of maximum KVA demand by intelligent program on instantaneous basis by controlling the furnace power. This increases furnace load factor (an important requirement of electricity board) and results in overall reduction of power consumption.
- Power optimization of the furnace by automatic cut/off of furnace capacitors depending on the load conditions.
- Recording and storage of data related to furnace weight (load cells to be provided) and metal temperature.
- Heat-wise power consumption, daily, weekly and monthly power consumption reports can be generated. All the generated reports can be printed.
- Remote web access through internet from any location in the world.
- Fiber optic network used for faster and noise free communication.

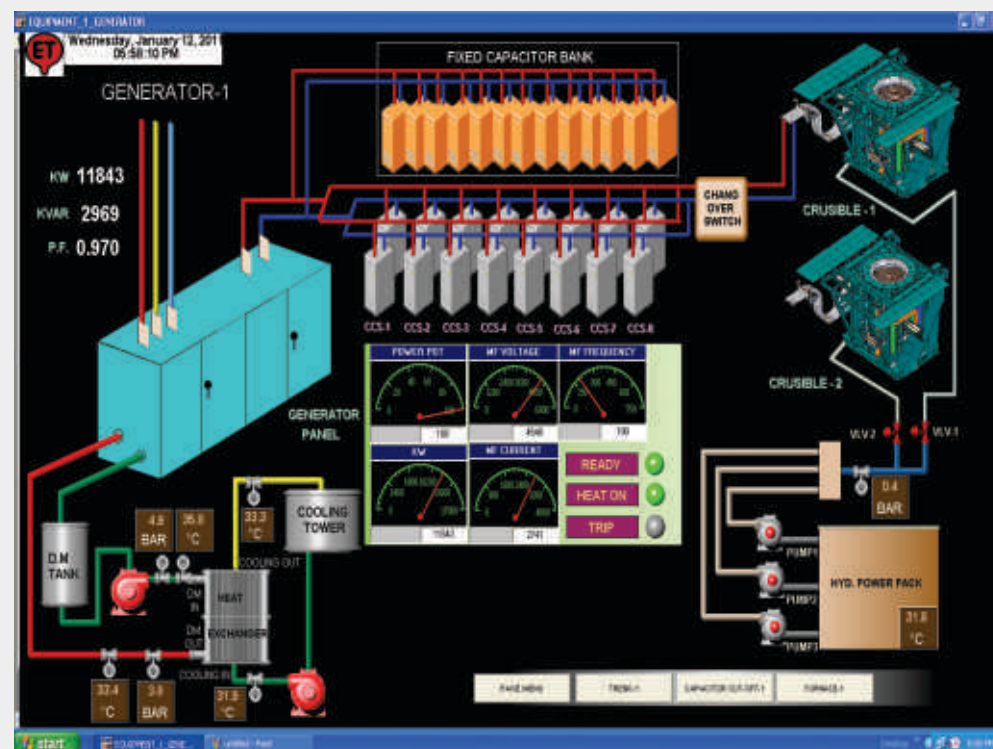

AUTOMATION



DYNAVAR



C-SMART

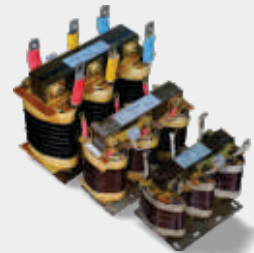

Detuned Filter Reactor

DYNAVAR - DYNAMIC REACTIVE POWER COMPENSATION SYSTEM

Key features and benefits include

- Compact modular design.
- Maintains Power Factor of 0.98 or better even at light load conditions ensuring effective reduction in KVA demand at all operating conditions.
- Uses C-SMART thyristor switch with an average response time of 10 ms.
- Uses detuned filter reactor to protect capacitors from overloading due to voltage harmonics.
- Low loss heavy duty capacitors are used.
- Fully automatic control of reactive power.
- Fast switching to match dynamic Loads.
- No separate circuit breaker is required.

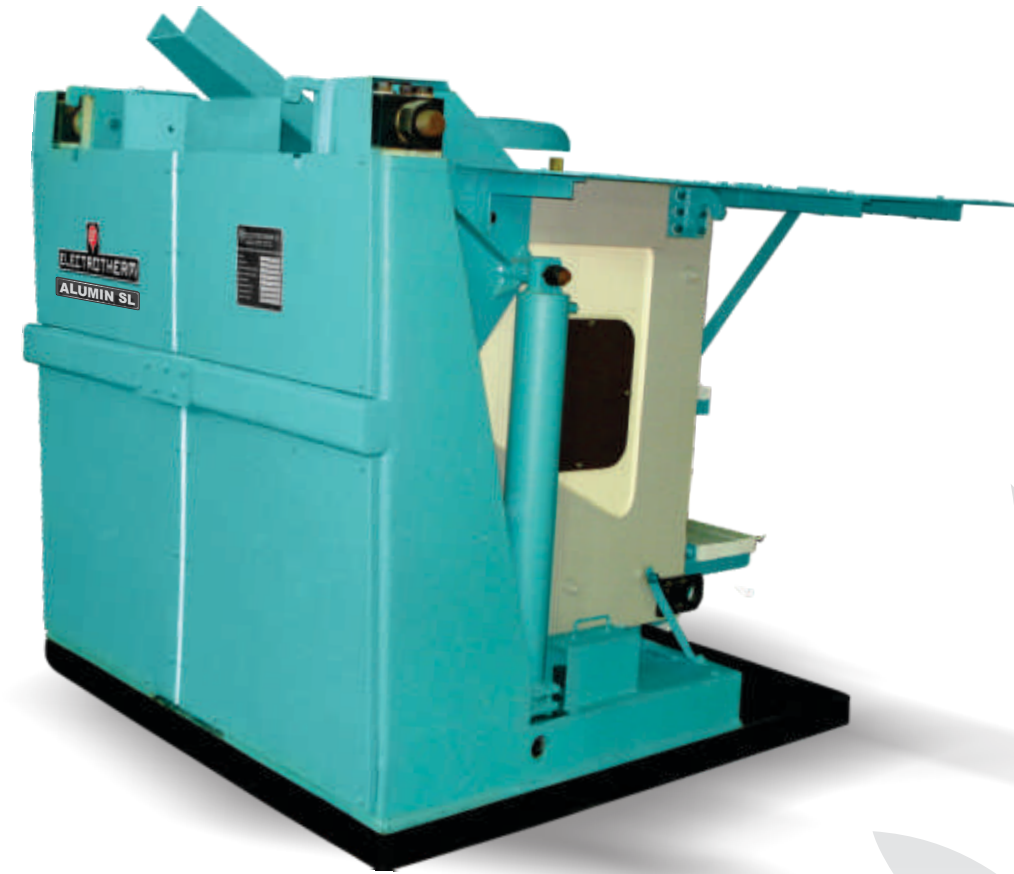

1 Ton Alumin SL Melting Furnace

ET ALUMIN-SL FURNACE

- Ideal for relatively small ferrous and non ferrous foundries.
- Available in capacities from 1 Kg to 1000 Kg.
- Rigid furnace construction with aluminium side plates and top & bottom castable refractory blocks.
- Special coil insulation prevents inter turn sparking.
- Coil supports maintain inter turn gap and enhance the rigidity of the coil assembly.
- Thick extruded rectangular section coils are used for higher electrical efficiency coupled with coil strength and rigidity.
- Stainless steel tie rods provide additional coil support.
- Lower vibration resulting in longer refractory life.
- Easier and faster installation.
- Easier maintenance with minimum down time.



12 Ton Steel Frame Melting Furnace

ET-STEEL FRAME MELTING FURNACES

- ET Steel frame melting furnaces are available in capacities ranging from 500 Kg to 50 Tons.
- These furnaces are ruggedly built with heavy structural steel for trouble free operation under harsh melt shop conditions.
- Thick walled rectangular coil sections are used to minimize coil losses.
- Special coil insulation prevents inter turn sparking.



50 Ton Steel Frame Holding Furnace

ET- STEEL FRAME HOLDING FURNACES

- Coil supports maintain inter turn gap and enhance the rigidity of the coil assembly.
- Insulated furnace lid is provided to reduce heat loss through radiation.
- Fume extraction ring / Fume extraction hood provided to capture smoke and fumes.

LOAD CELL ARRANGEMENT (Optional)



- Furnace load cells enable accurate recording of weight of charge material and liquid metal in the furnace resulting in simplification of weight calculations related to charge, alloy additions and metal tapping.
- Can be linked to PMA 100 or SPA 100 for continuous reading and monitoring of weight of the liquid metal in furnace.

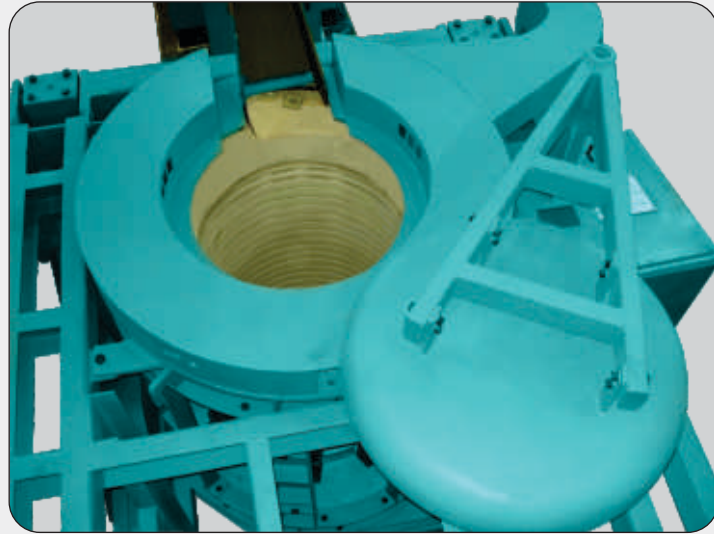

FUME EXTRACTION RING (OPTION 1)

- Sturdy construction, built with boiler quality steel and provided with refractory lining from inside.
- The fume extraction ring with furnace lid ensures that the smoke and fumes generated during melting do not escape outside.
- Designed for easier connection with air pollution control system's ducts.

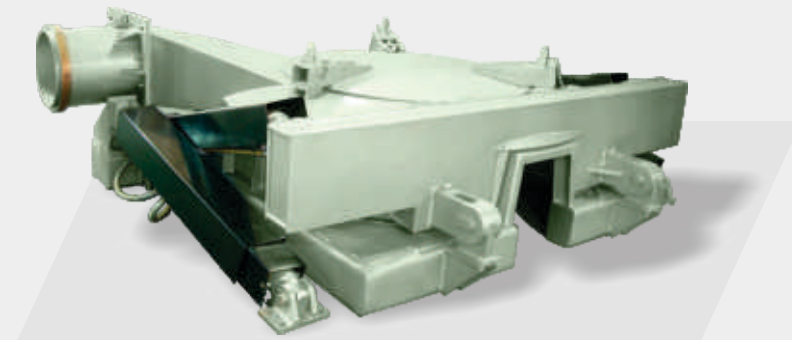

DOUBLE ACTING FUME EXTRACTING HOODS (OPTION 2)

- The fume extraction hood built from boiler quality thick steel sheet is refractory lined from inside and integrated with refractory lined lid.
- Can lift out to open from both front and back ends of the furnace to facilitate pushing out of the lining and furnace charging respectively.
- Sturdy construction to endure tough melt vicinity environment.



ET - Vibratory Charging System

- The vibratory feeder is mounted on a trolley which moves on rails to feed the furnace.
- A sturdily built hopper receives and stores the charge material to be fed to furnace.
- The feeder vibration ensures that the charge is well spread in the feeder and moves uniformly and smoothly in to the furnace.
- The feeder vibration at a suitable frequency is achieved by unbalanced motors.
- The design ensures keeping the noise level at a minimum during the charging process.
- The feeder movement from charge loading point to melt furnace is smooth.
- Power cable drag is strong and well designed to achieve longer life.

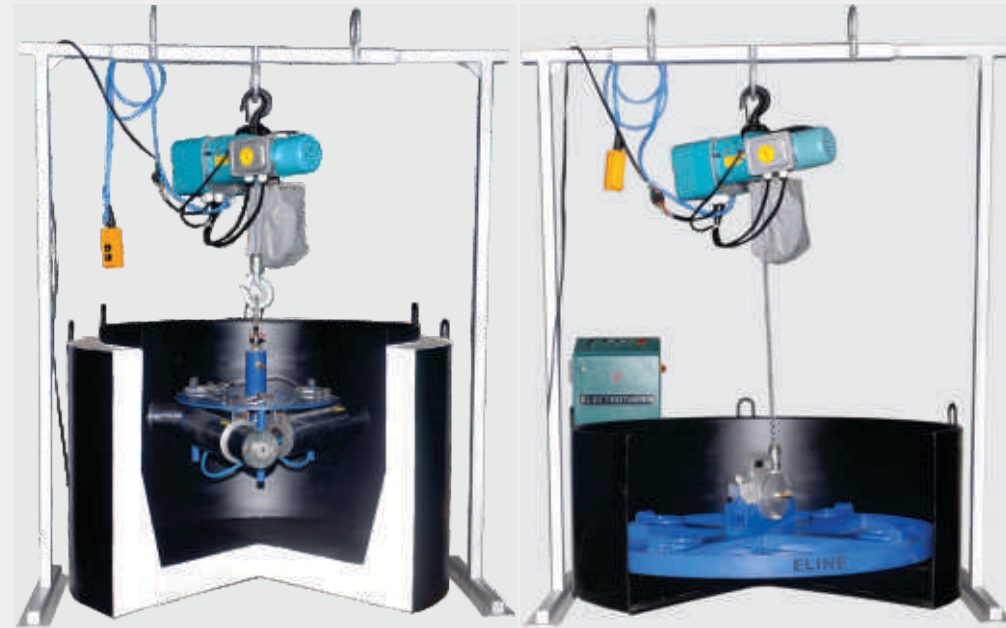

ET-ELINE-3 ARM PNEUMATIC LINING VIBRATORS

- Ensures compactness of lining.
- Uniform strength of Lining throughout the furnace.
- Increased Lining Life, predictable and increased output tonnage.
- Reduced relining time.
- Reduction in manpower for re-lining.
- Pollution-free lining.
- Smooth operation.

ET LINING PUSH OUT

- The lining push out system is hydraulically powered and is designed for smooth and quicker removal of refractory lining by applying even pressure on the refractory side walls.
- The entire refractory lining can be removed almost in one piece.



Furnace Transformers

- Electrotherm transformers are of high quality and reliability, designed to satisfy varied applications and technical requirement.
- Furnace transformer currently available in ratings up to 25 MVA, 33 KV.
- These transformers are designed, manufactured and tested to comply with various standards including IS, IEC, BS, ASTA or any standards as specified the customer.

Design considerations include;

- Frequent short circuit like condition, rapid and large load fluctuations.
- Cooling options, ONAN, ONAF, OFWF or any appropriate to meet application need.
- Double tier (HV and LV windings in two layer) for 12 pulse and additional shift winding for 24 pulse and above.
- Avoiding structural heating due to very high current on secondary side by mounting secondary terminal on large insulating plate.



ET-Pushout Furnace

The PUSHOUT furnace is a highly efficient crucible melting system. After completing melting in a crucible, the crucible is pushed out hydraulically / mechanically and taken out for pouring. This avoids heat loss and oxidation during liquid metal transfer from crucible to ladle. The coils are lined from inside with refractory cement to guard against spillage.

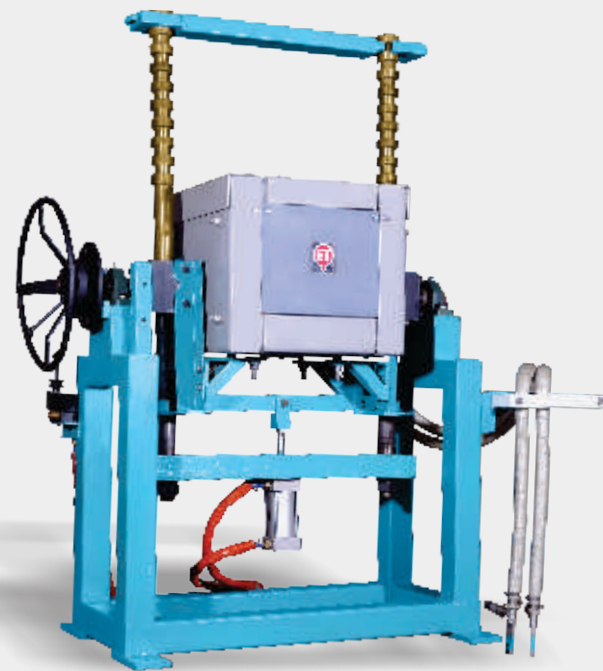

ET-Rollover Furnace

Electrotherm's Rollover furnace is ideal for close control of pouring to produce high quality investment castings. In rollover furnaces, metal flows directly from the furnace into the mould with minimum air and refractory contact, limiting both oxidation and refractory inclusions. Also, the centrifugally assisted metal flow obtained during rollover ensures that moulds are filled quickly and completely.



ET-AUTOPOUR-UH -Vision Controlled Unheated Automatic Pouring System

- Suitable for grey and ductile iron pouring.
- Available in capacities from 1 Ton to 3 Ton.
- Key benefits include increased production, increased casting yield, reduced pouring related rejections, drastic reduction metal spillage and lower labor cost.
- Strong construction, rigidly built for longer life.
- Robust hydraulic system (with standby pump), heavy duty hydraulic cylinders and secured hardware design for smooth movement X-Y carriage.
- The servo stopper rod mechanism ensures a very fast stopper response and accurate control to achieve consistent pours mould after mould.
- Accuracy and repeatability of ET-AUTOPOUR system's pours are self adaptive to take care of change in metal levels and temperature.
- The pouring vessel can be filled with metal even while pouring is in progress without in any way disrupting the pouring operation.
- ET-AUTOPOURS use latest generation PLC system with touch screen display for accurate control of the pouring.